

CHARACTERISTICS:

- KNX 3.8" back-lighted monochrome Touch Panel
- Room Thermostat
- 12 configurable direct control functions
- 6 additional screens with up to 6 functions each:
 - Scenes
 - Alarms
 - Schedule programming
 - Climate Management
 - Display parameters
- IR receiver
- 4 binary inputs for potential free push buttons
- Only bus connection is required
- No Power Supply different from the BUS required
- KNX BCU included
- Complete Data Saving in case of Power Failure
- CE directives OK

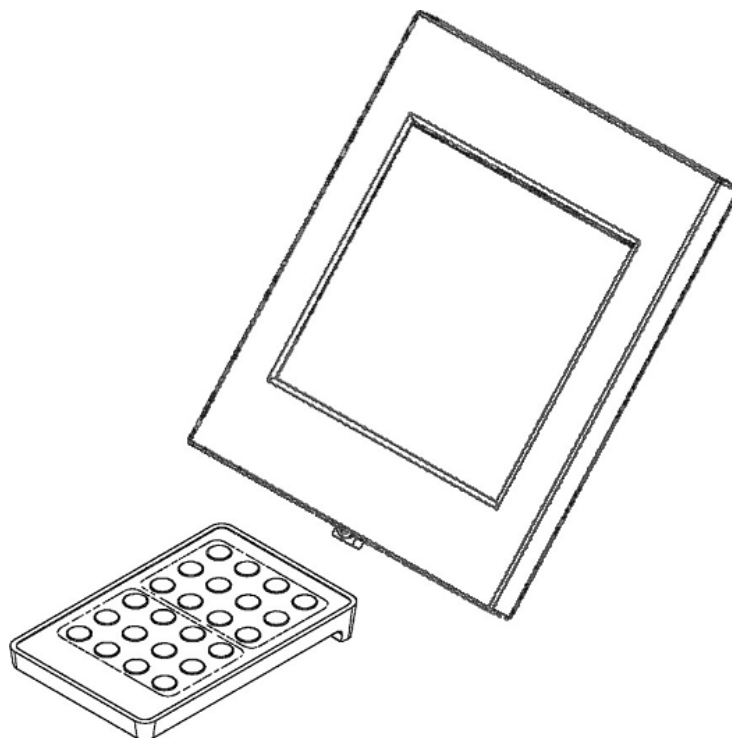

CONCEPT		DESCRIPTION
○ Device Type		Electric Operation Control Device
○ EIB/KNX Supply	○ Voltage	29V DC SELV
	○ Voltage range	20...31V DC
	○ Consumption	480mW (two pay loads)
	○ Connection Type	Typical BUS connector TP1, 0,50 mm ² section
○ External Power Supply		No
○ Operating Temperature		0° C to +45° C
○ Storage Temperature		-20° C to +60° C
○ Ambient humidity (relative)		30 to 85% RH (no condensation)
○ Storage humidity (relative)		30 to 85% RH (no condensation)
○ Complementary characteristics		Class B
○ Safety class		II
○ Operation type		Continuous operation
○ Device action type		Type 1
○ Electrical solicitations period		Long
○ N° of Automatic cycles per auto action		100.000
○ Type of Protection		IP20. Clean environment
○ Assembly		Independent Control Assembly device Vertical position, with the IR receiver and the temperature sensor to the bottom. See "installation figure"
○ Minimum clearances		Keep away from heat and cold air flows to get better temperature sensor measures
○ Response to BUS voltage failure		Complete data saving
○ Response to BUS failure recovery		Before Failure Data recovery
○ Function indicator		Several on Display as programmed
○ Accessories		IR Remote Control (optional)
○ PCB CTi index		175 V
○ Enclosure		PC-ABS, flammability category class D
○ Weight		250 gr.

Dimensions and descriptions.

- **Prog.:** used to select the device programming mode. If initially pressed and kept, after bus connection, “secure mode” is set.
- **Led:** Led “on” indicates programming mode. Led “on” and “off” alternatively every 0,5s, the device is in “secure mode”

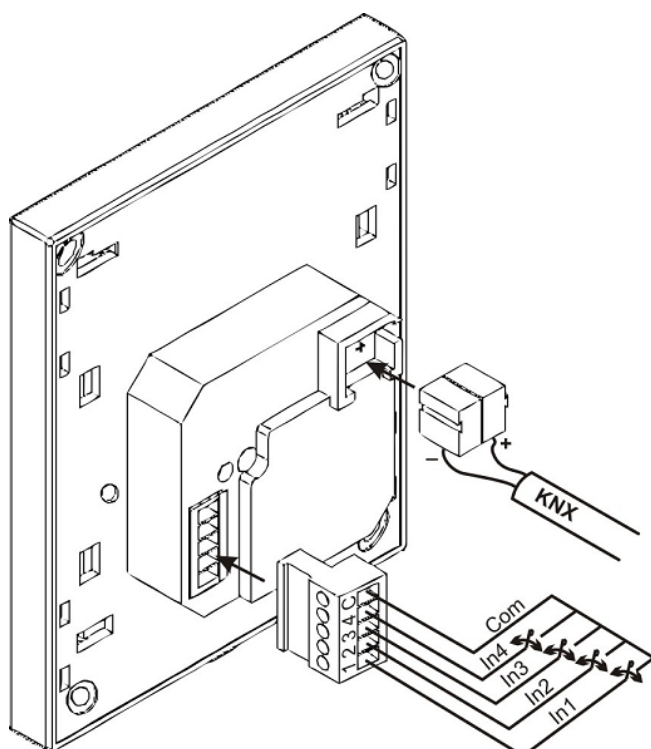
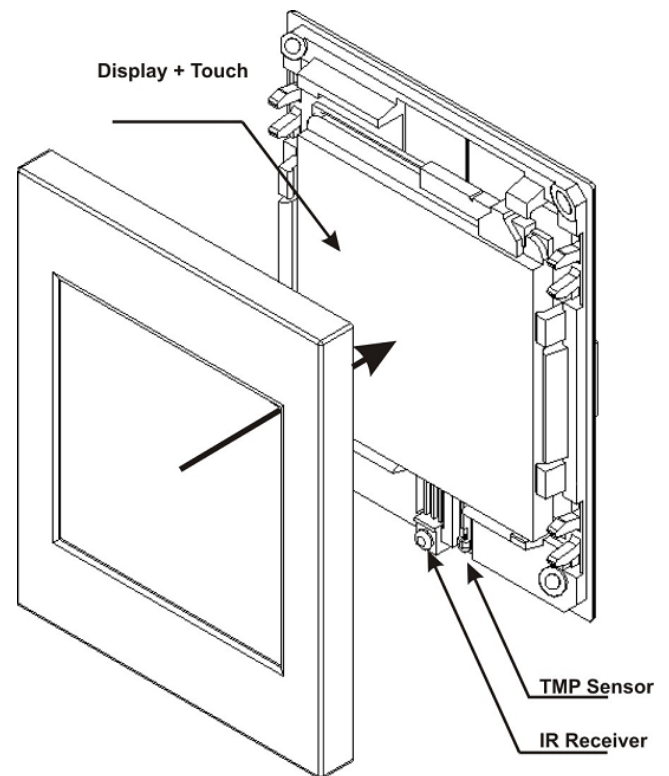
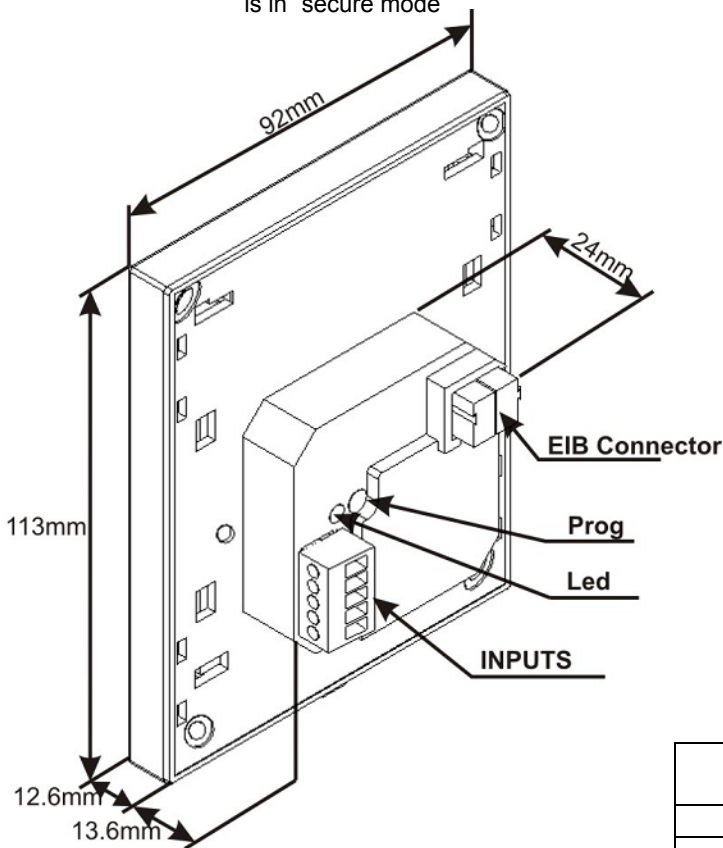

Inputs-Specifications and connections

CONCEPT		DESCRIPTION	
o	Isolation method	Optical coupler	
o	Input voltage	+5V DC for the common	
o	Voltage range	---	
o	Input current	1,0mA at 4,75V DC in every input	
o	Inputs per common	4	
o	Input impedance	Aprox. 4,7kΩ	
o	Switching type	Through potential free contacts between Input and Common	
o	Connection Method	Screw terminal clamp	
o	Max. Cable length	15 m.	
o	Cable Section	0,15 mm ² to 1 mm ²	
o	Response Time	OFF → ON	Max 10 ms
		ON → OFF	Max 10 ms
o	Number of inputs	Up to 4	

- o Input Clamp consists of 4 individual binary inputs and 1 common. A **Close Contact** results from joining an Input with the global “Common”.

Installation Figure (Read this completely before starting the installation):

1. The basic enclosure piece (the one including the display) must be placed into a standard squared/rounded box (minimum diameter 65mm), as shown in figure below. Inputs and BUS clamps must be previously connected.
2. Binary inputs screw Terminal-Clamp should be pre-wired to avoid re-installing the touch panel.
3. Dismantling the display from the Basic enclosure piece invalidates the original warranty.
4. You are recommended to use a level tool to install the basic enclosure piece in the right position by parking the points where the wall fixings will be inserted.
5. Once the wall fixings are inserted (unnecessary in wooden walls), the Basic enclosure piece must be screwed with the right tightness to get a good fastening but avoiding any deformation on the piece.
6. Remove the plastic foil protector (thin plastic film) from the display before installing the cover.
7. Install the cover by pressing on the four fixing points.
8. If uninstalling the device is mandatory, the cover would be dismantled by using a plain fork or small knife, introducing these tools as much as possible between the cover and the Basic enclosure, near the fixing points, to avoid any superficial damage to both pieces.

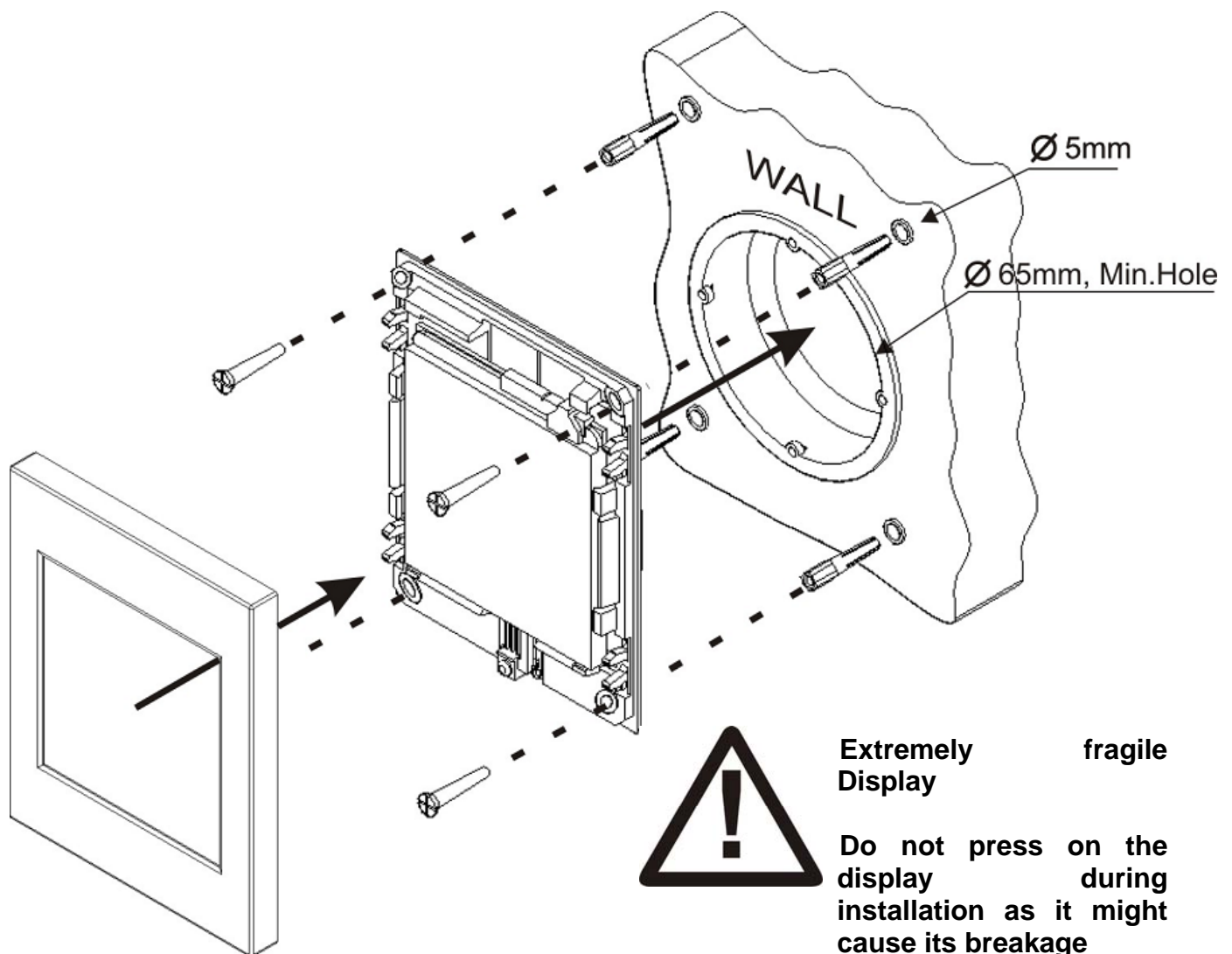

- Once installed, the Touch Panel will be configured via ETS.
- When the download is finished, you should touch the corner 1 and, afterwards, the corner 2 to define the touch zone.
- These limits are saved by the device even after a Bus Voltage Failure.
- Nevertheless, after every ETS download you should touch again the corners 1 and 2
- **Programming Mode can be set, via the display, as follows: Menu → Tools → programming (upper left corner) → ON.** To keep this option, it is necessary to configure it in ETS parameters.
- Enabling the **“Contrast”** and **“Programming”** functions included in the CONFIGURATION section is recommended for any device configuration

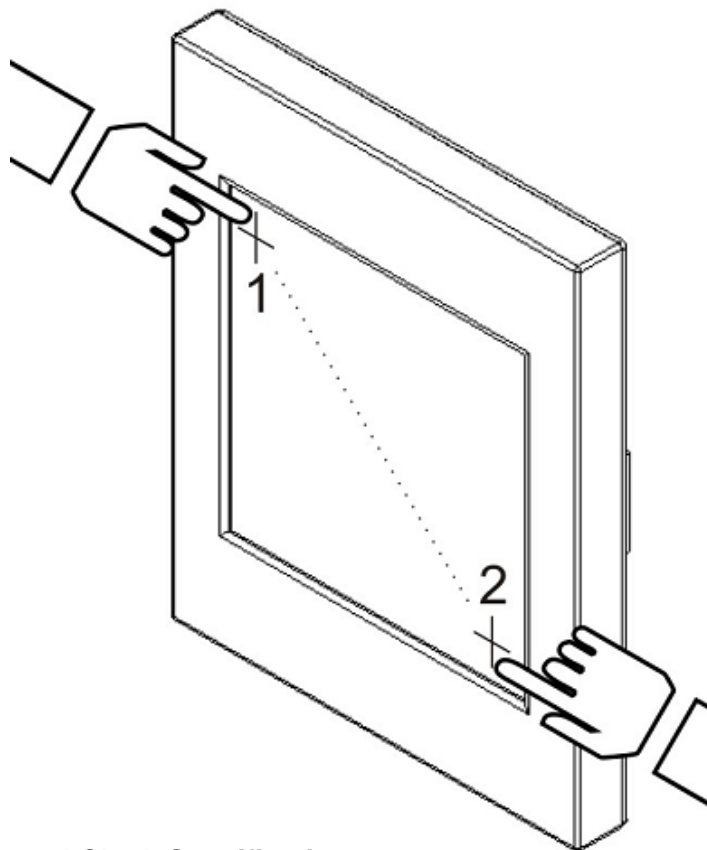

■ Room Temperature Regulator and Internal Clock Specifications.

CONCEPT	DESCRIPTION
○ Measuring range	0° C to +40° C
○ Resolution	0,1 K
○ Sensor precision	± 0,5° C
○ Internal clock resolution	1 minute
○ Time error	To keep the time error low, set and thus update the internal clock via the bus every hour.
○ Date/Time Set	Manual: Set from screen Auto: Through BUS telegrams from a KNX clock
○ Response to Bus Power Failure	Internal clock saves last time displayed
○ Response to Bus Power Recovery	Internal clock recovers last time displayed

General Care

Clean the product with a clean, soft, damp cloth. Do not use aerosol sprays, solvents, or abrasives that might damage the INZennio Z38 finish.



SAFETY INSTRUCTIONS

- **Do not connect the Main Voltage (230 V) or any other external voltages to any point of the BUS.**
- **Connecting an external voltage might put all the EIB/KONNEX system into risk.**
- Ensure there is enough insulation between the AC Voltage cables and the BUS ones.
- To prevent EMC interference, avoid running input cables in parallel with the Main Voltage ones.